

MS1

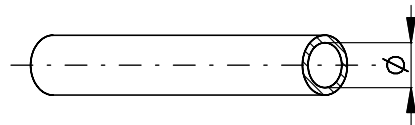
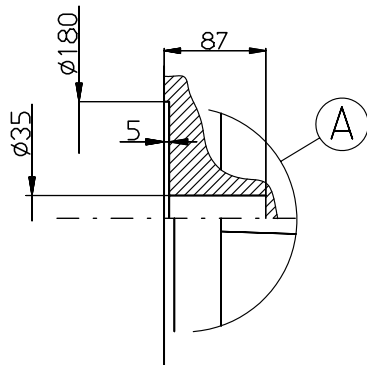
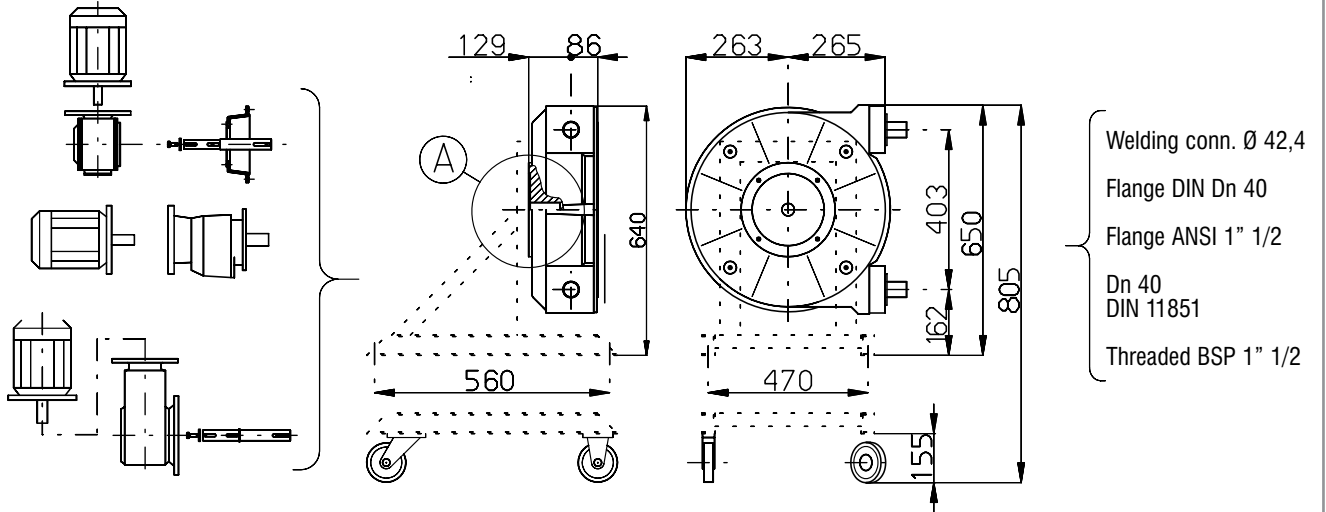
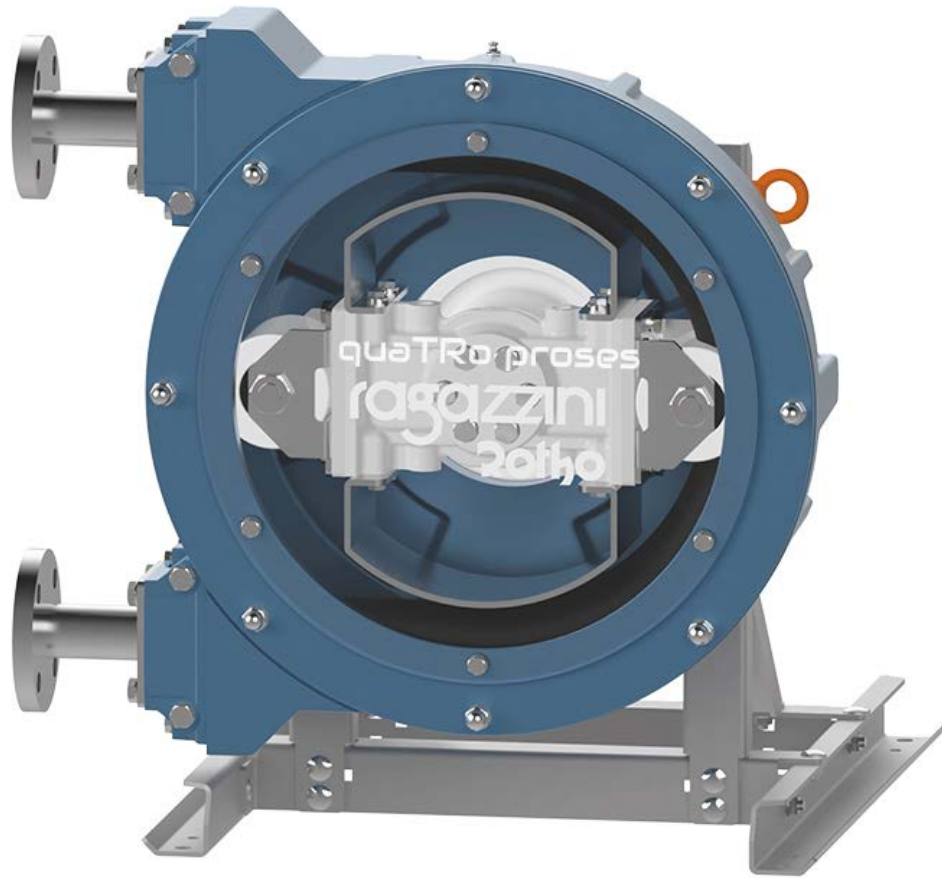

TECHNICAL DATA			
MOD.	Ø mm	LT/RPM	MAX BAR
MS1	40	1,40	8-15

0-4 bar				
RPM	Lt/h	BAR		Kw
		std	max	
14	1114	2	4	0,75
18	1447	2	4	0,75
22	1779	2	4	0,75
25	2029	2	4	1,5
30	2445	2	4	1,5
35	2861	2	4	1,5
47	3859	2	4	1,5
61	5024	2	4	2,2
70	5773	2	4	2,2
93	7686	2	4	3

4-8 bar				
RPM	Lt/h	BAR		Kw
		std	max	
14	1090	4	8	0,75
15	1172	4	8	0,75
17	1335	4	8	0,75
19	1498	4	8	1,5
22	1742	4	8	1,5
24	1905	4	8	1,5
27	2150	4	8	1,5
30	2394	4	8	1,5
35	2802	4	8	1,5
38	3046	4	8	2,2
45	3617	4	8	2,2
49	3943	4	8	2,2
56	4513	4	8	2,2
62	5002	4	4	2,2
71	5906	2	2	2,2
79	6572	2	2	2,2
89	7404	2	2	2,2

8-12 bar				
RPM	Lt/h	BAR		Kw
		std	max	
14	843	8	12	1,5
15	918	8	12	1,5
17	1067	8	12	1,5
19	1217	8	12	2,2
22	1441	8	12	2,2
24	1590	8	12	2,2
27	1815	8	12	2,2
30	2039	8	12	3
35	2413	8	12	3
38	2637	8	12	3
45	3160	8	12	3
49	3459	8	8	3
56	3982	8	8	3
62	4430	8	8	3
71	4849	8	6	3
79	5447	8	4	3
89	6194	8	4	3

15 bar				
RPM	Lt/h	BAR		Kw
		std	max	
14	217	15	15	1,5
15	277	15	15	1,5
17	397	15	15	1,5
19	517	15	15	2,2
22	697	15	15	2,2
24	816	15	15	2,2
27	996	15	15	2,2
30	1176	15	15	3
35	1476	15	15	3
38	1655	15	15	3
45	2075	15	15	4

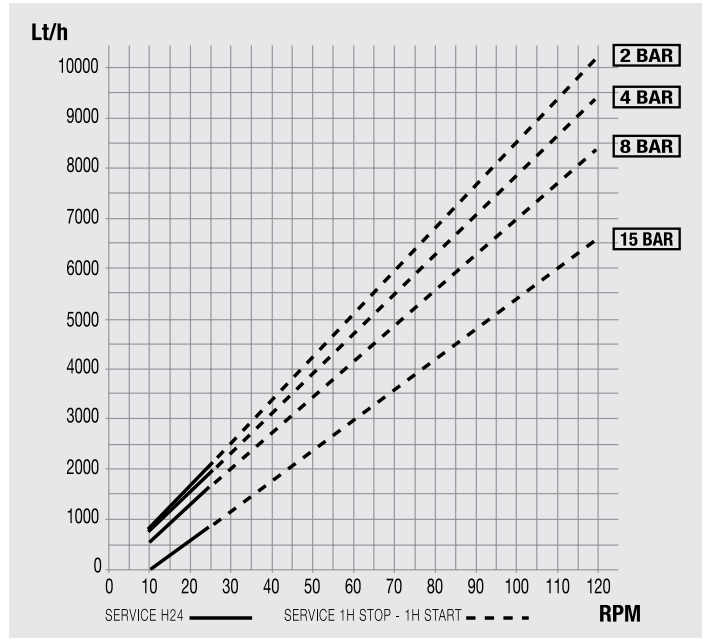

variable gear speed 0-4 bar						
RPM		Lt/h		BAR		Kw
max	min	max	min	std	max	
10	1,9	781	107	2	4	0,75
13	2,4	1031	149	2	4	0,75
16	3	1280	199	2	4	0,75
18	3,4	1447	232	2	4	0,75
22	4,1	1779	290	2	4	1,5
25	4,8	2029	349	2	4	1,5
33	6,3	2695	473	2	4	1,5
43	8,3	3526	640	2	4	1,5
50	9,5	4109	740	2	4	1,85
67	12,7	5523	1006	2	2	1,85
100	19	8268	1530	2	2	2,2

variable gear speed 4-8 bar						
RPM		Lt/h		BAR		Kw
max	min	max	min	std	max	
10	1,9	764	104	4	8	0,75
11	2	846	112	4	8	0,75
12	2,3	927	137	4	8	0,75
13	2,6	1009	161	4	8	1,5
16	3	1253	194	4	8	1,5
17	3,2	1335	210	4	8	1,5
19	3,7	1498	251	4	8	1,5
21	4	1661	275	4	8	1,5
25	4,7	1987	332	4	8	1,85
27	5,2	2150	373	4	8	1,85
32	6,1	2557	446	4	8	2,2
35	6,7	2802	495	4	8	2,2
40	7,6	3209	569	4	8	3
44	8,4	3535	634	4	8	3
51	9,6	4106	732	4	8	3
56	10,7	4513	821	4	6	3
63	12	5084	927	4	6	3
89	17	7203	1335	4	4	3