

# SF190

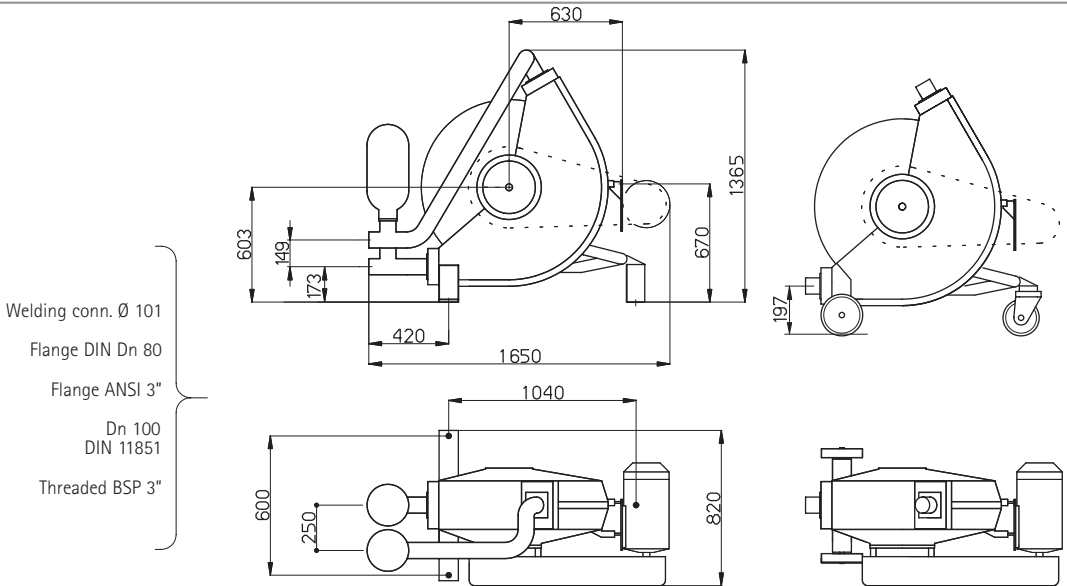

TECHNICAL DATA			
MOD.	Ø mm	LT/RPM	MAX BAR
SF	90	14,5	8-15

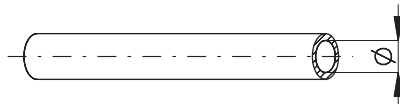

0-4 bar				
RPM	Lt/h	BAR		Kw
		std	max	
14,9	11706	2	4	5,5
19,6	15449	2	4	5,5
23,6	18635	2	4	5,5
28,1	22220	2	4	7,5
29,7	23494	2	4	7,5
35,5	28114	2	4	11
39,7	31459	2	4	11
41,8	33132	2	3,5	11

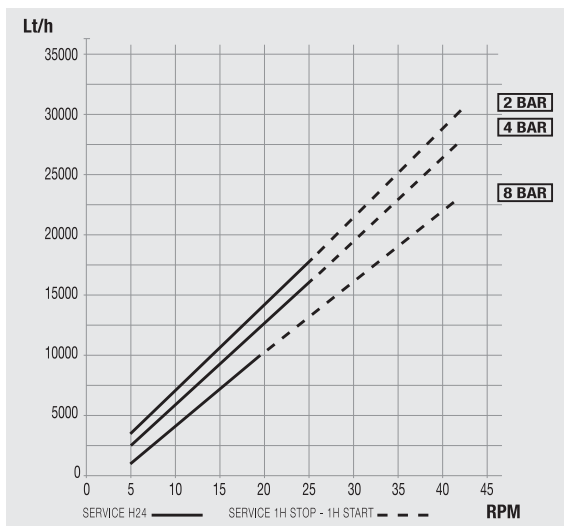

4-8 bar				
RPM	Lt/h	BAR		Kw
		std	max	
16,9	13025	4	8	11
18,8	14508	4	8	11
21,4	16536	4	8	11
23,9	18487	4	8	11
26,8	20750	4	8	15
30,1	23325	4	8	15
33,6	26056	4	8	15
37,6	29177	4	7	15
41,8	32455	4	6	15

8 bar				
RPM	Lt/h	BAR		Kw
		std	max	
16,9	11444	8	8	11
18,8	12803	8	8	11
21,4	14664	8	8	11
23,9	16452	8	8	11
26,8	18527	8	8	15
30,1	20889	8	8	15
33,6	23393	8	8	15
37,6	26255	7	8	15
41,8	29260	6	8	15

Variable gear speed 0-3,5 bar						
RPM		Lt/h		BAR		Kw
max	min	max	min	std	max	
20,1	3,8	15848	2865	2	3,5	5,5
25,2	4,8	19910	3661	2	3,5	7,5
30	5,7	23733	4378	2	3,5	7,5
36,1	6,9	28592	5334	2	3	9,2
42,9	8,2	34008	6369	2	2,5	9,2

Variable gear speed 4-8 bar						
RPM		Lt/h		BAR		Kw
max	min	max	min	std	max	
19,4	3,3	14976	2413	4	8	11
24,3	4,1	18799	3037	4	6	11
34,7	5,9	26914	4442	4	5	11
38,7	6,6	30036	4988	4	4	11